

TC50G1.....P01
Threaded reservoir

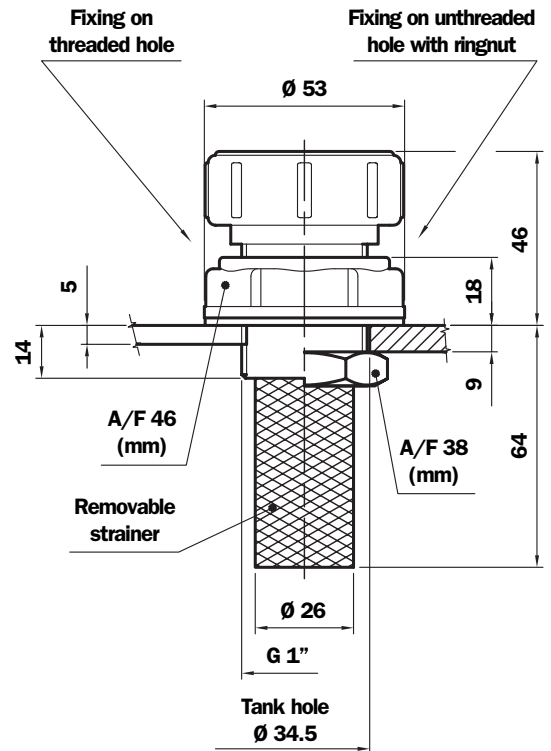

Dimensions



TC50GA.....P01
Unthreaded hole in reservoir



TC50 ((Materials))

- 1 - Cover: Nylon
- 2 - Filter element: Galvanised Steel
- 3 - Filler cap: Nylon
- 4 - Strainer: Galvanised Steel/Nylon
AISI 304 Nylon
- 5 - Collar: Nylon
- 6 - Seal: Inorganic fibre
- 7 - Ringnut: Phosphated Steel

Weight

TC 50 G1: 0,070 Kg
TC 50 GA: 0,100 Kg

Ordering information

Filler cap	1	2	3	4	5	6	7
TC50	<input type="checkbox"/>	<input type="checkbox"/>	<input type="checkbox"/>	<input type="checkbox"/>	<input type="checkbox"/>	<input type="checkbox"/>	<input type="checkbox"/>
Example: TC50	G1	L90	P	R	O	C70	P01

1 - Connection

<input type="checkbox"/> G1	G 1"
<input type="checkbox"/> GA	With ringnut

2 - Filter element

<input type="checkbox"/> L90	Galvanised steel
-------------------------------------	------------------

3 - Seal

<input type="checkbox"/> P	Inorganic fibre
-----------------------------------	-----------------

4 - Cover colour

<input type="checkbox"/> R	Red
<input type="checkbox"/> G	Yellow

5 - Cover wording

<input type="checkbox"/> O	Oil
<input type="checkbox"/> N	Neutral

6 - Basket

<input type="checkbox"/> C70	Basket L= 70 - Galvanised Steel
<input type="checkbox"/> I70	Basket L= 70 - AISI 304
<input type="checkbox"/> S	Without

7 - Options

<input type="checkbox"/> P01	MP Filtri standard
-------------------------------------	--------------------